

40 x 40

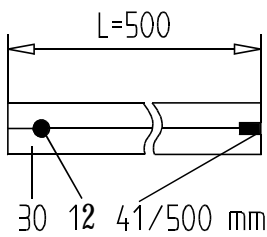
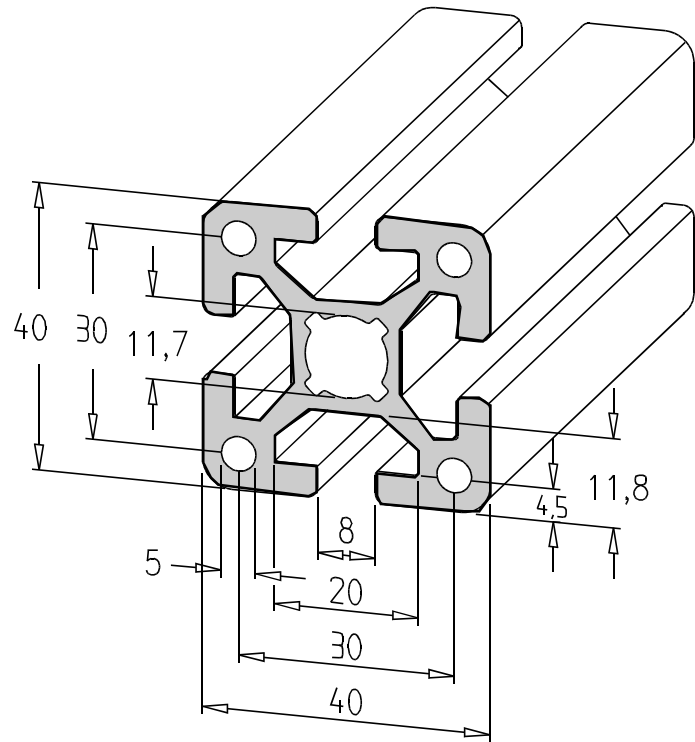

	10 x 6000 mm			30 00 00/6000 mm
	1 x 6000 mm			30 00 01/6000 mm
				30 02 02/..... mm
				30 12 02/..... mm
				30 12 12/..... mm
	M8x20			30 41 02/..... mm
	M8x20		M8x20	30 41 41/..... mm
	M14x100			30 47 02/..... mm
	M14x100		M14x100	30 47 47/..... mm
	M8x20			30 41 12/..... mm
	M14x100			30 47 12/..... mm
	45°			30 32 02/..... mm
	45°		45°	30 32 32/..... mm

Nach Bearbeitungsliste Seite 2.0.5–2.0.6 bzw. nach Ihrer Skizze

Compare outline of end finishing page 2.0.5–2.0.6, res. raccording to your own sketch

30 99 99/..... mm

Selon som aire de usinage des extrémités page 2.0.5–2.0.6, ou bien votre propre dessin

Conforme a la tabella de la lavorazione delle estremita pagina 2.0.5–2.0.6, rispett. schizzo costrutivo

Ver listo de mecanizar los extremos pag. 2.0.5–2.0.6, o ben segu un esbozo de Ud.