

45 x 90

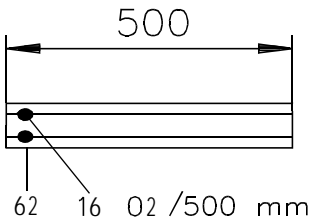
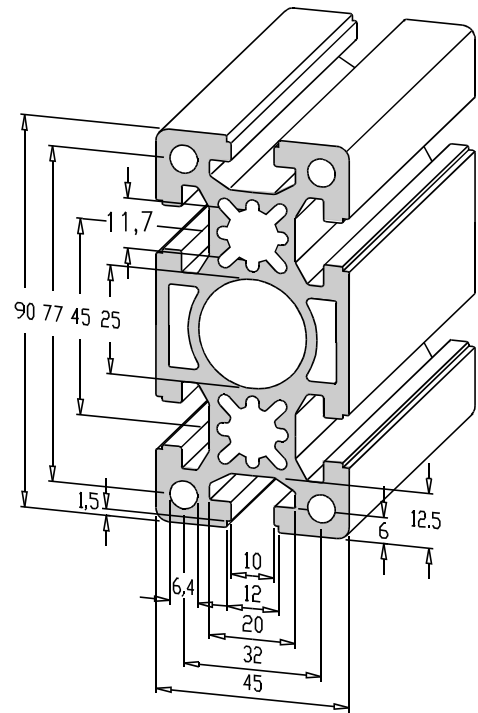

	5 x 6000 mm		62 00 00/6000 mm
	1 x 6000 mm		62 00 01/6000 mm
			62 02 02/..... mm
			62 16 02/..... mm
			62 16 16/..... mm
			62 15 02/..... mm
			62 15 15/..... mm
	M8x20 (2x)		62 42 02/..... mm
	M8x20 (2x)	M8x20 (2x)	62 42 42/..... mm
	M14x100 (2x)		62 48 02/..... mm
	M14x100 (2x)	M14x100 (2x)	62 48 48/..... mm
	45°	45°	62 35 35/..... mm
	45°	45°	62 36 36/..... mm

Nach Bearbeitungsliste Seite 3.0.5–3.0.6 bzw. nach Ihrer Skizze

Compare outline of end finishing page 3.0.5–3.0.6, res.raccording to your own sketch

62 99 99/..... mm

Selon sommaire de usinage des extrémités page 3.0.5–3.0.6, ou bien votre propre dessin

Conforme a la tabella de la lavorazione delle estremita pagina 3.0.5–3.0.6, rispett. schizzo costruttivo

Ver lista de mecanizar los extremos pag. 3.0.5–3.0.6, o bien segun un esbozo de Ud.