

45 x 60

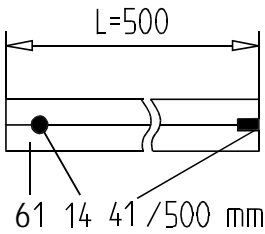
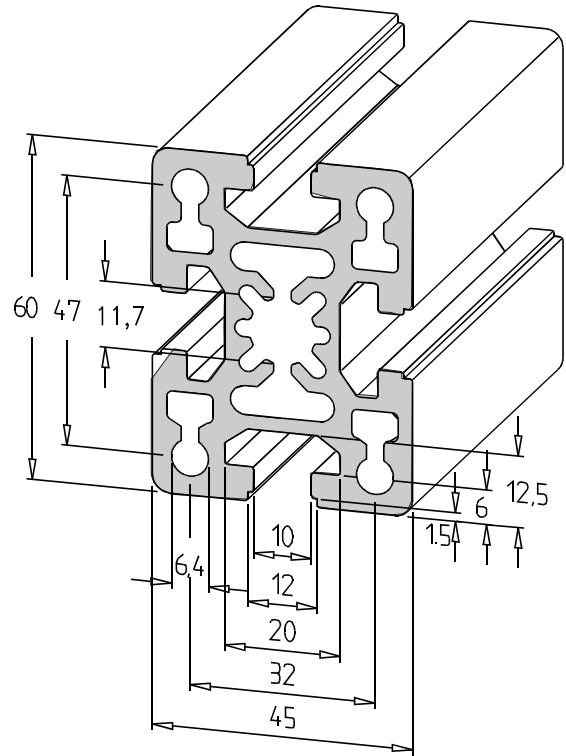

	10 x 6000 mm		61 00 00/6000 mm	
	1 x 6000 mm		61 00 01/6000 mm	
			61 02 02/..... mm	
			61 14 02/..... mm	
			61 14 14/..... mm	
			61 13 02/..... mm	
			61 13 13/..... mm	
	M8x20		61 41 02/..... mm	
	M8x20		M8x20	61 41 41/..... mm
	M14x100		61 47 02/..... mm	
	M14x100		M14x100	61 47 47/..... mm
	45°		45°	61 33 33/..... mm
	45°		45°	61 34 34/..... mm

Nach Bearbeitungsliste Seite 3.0.5–3.0.6 bzw. nach Ihrer Skizze

Selon sommaire de usinage des extrémités page 3.0.5–3.0.6, ou bien votre propre dessin

Ver lista de mecanizar los extremos pag. 3.0.5–3.0.6, o bien segun un esbozo de Ud.

Compare outline of end finishing page 3.0.5–3.0.6 res. according to your own sketch

Conforme a la tabella de la lavorazione delle estremita pagina 3.0.5–3.0.6, rispett. schizzo costruttivo

61 99 99/..... mm