

45 x 45

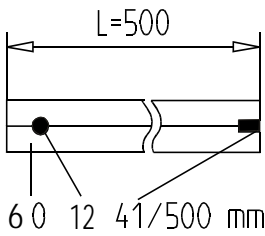
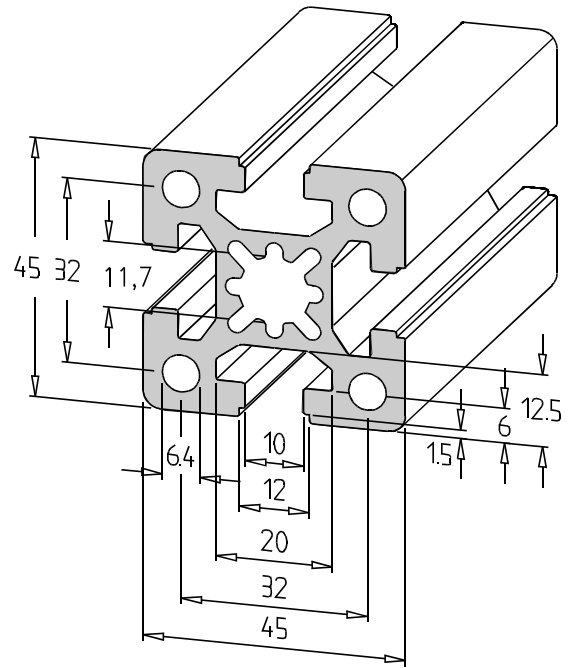

	10 x 6000 mm			60 00 00/6000 mm
	1 x 6000 mm			60 00 01/6000 mm
				60 02 02/..... mm
				60 12 02/..... mm
				60 12 12/..... mm
	M8x20			60 41 02/..... mm
	M8x20		M8x20	60 41 41/..... mm
	M14x100			60 47 02/..... mm
	M14x100		M14x100	60 47 47/..... mm
	M8x20			60 41 12/..... mm
	M14x100			60 47 12/..... mm
	45°			60 32 02/..... mm
	45°		45°	60 32 32/..... mm

Nach Bearbeitungsliste Seite 3.0.5–3.0.6 bzw. nach Ihrer Skizze

Compare outline of end finishing page 3.0.5–3.0.6, res. according to your own sketch 60 99 99/..... mm

Selon sommaire de usinage des extrémités page 3.0.5–3.0.6, ou bien votre propre dessin

Conforme a la tabella de la lavorazione delle estremita pagina 3.0.5–3.0.6, rispett. schizzo costruttivo

Ver listo de mecanizar los extremos pag. 3.0.5–3.0.6, o bien segun un esbozo de Ud.